

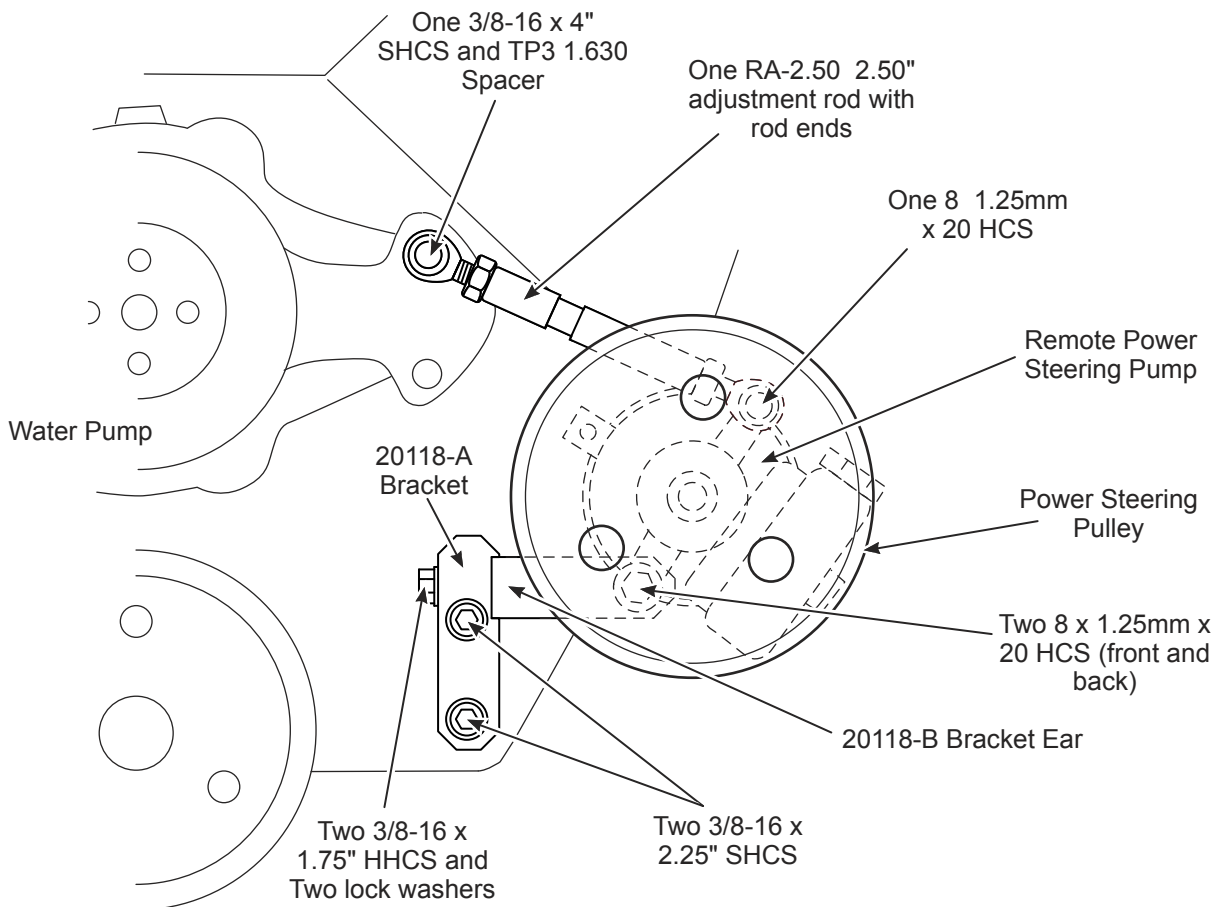

20118 Chevy Small Block Adjustable Power Steering Bracket

Remote Style Power Steering Pump



1. Bolt (20018-B) Ear to (20118-A) Bracket using two 3/8-16 X 1 3/4" hex head screws & two lock washers (leave loose to adjust)
2. Bolt (20018-B) Ear to power steering pump using two 8 x 1 .25mm X 20mm hex head screws from front and back of power steering pump (leave loose to swivel)
3. Bolt (20118-A) Bracket to engine block using two 3/8-16 X 2 1/4" socket head cap screws
4. Bolt (RA-2.500) SS Rod Assembly end to power steering pump using one 8 x 1 .25mm X 20mm hex head screw.
5. Press power steering pulley on to power steering pump
6. Align power steering pulley to crank pulley using a straight edge & tape measure
7. Tighten (20018-B) Ear to (20118-A) Bracket after aligning
8. Install Belt
9. Bolt other end of (RA-2.500) SS Rod Assembly to engine block thru water pump mounting holes using one 3/8-16 X 4" socket head cap screw & one (TP3 1.630) Spacer, placing Spacer between Rod end & water pump.
10. Adjust belt tension using (RA-2.500) SS Rod Assembly
11. Tighten (20018-B) Ear to power steering pump
12. Tighten (RA-2.500) SS Rod Assembly nuts

High Water Flow 7" Crank Pulley use:
(15365) 36 1/2" Dayco V-belt

High Performance 5 1/2" Crank Pulley use:
(526) P/S Pulley
(15345) 34 1/2" Dayco V-belt

Serpentine Belt Pulley:
(5060360) 36" 6-rib Dayco serpentine belt

High Performance Crank Pulley use:
(619) P/S Pulley
(5050340) 34" 5-rib Dayco serpentine belt